



# VALVE POSITION MONITOR APL - SERIES



APL series valve position monitor provides high reliability and for your automation plan.

**WEATHERPROOF  
EXPLOSIONPROOF**





# LIMIT SWITCH BOX

## Valve Position Monitor APL-SERIES

Made In Korea

	<p style="text-align: center;"><b>MODEL : APL - 2N SERIES (APL-210N)</b></p> <ul style="list-style-type: none"> <li>- Enclosure : Weatherproof IP67/NEMA4&amp;4X (Standard ) IP68(Optional)</li> <li>- Solid and compact design</li> <li>- Bolts on visual position indicator (Re-adjustment available upon required direction)</li> <li>- Dual cable entries : 2 x 1/2 NPT(Standard)</li> <li>- Terminal Strips : 8 points(0.08-2.5mm<sup>2</sup>)</li> <li>- Captive cover bolts</li> <li>- Easy mounting bracket</li> <li>NAMUR standard stainless steel shaft and bracket.</li> <li>- <b>Stainless steel (316) housing as option</b></li> </ul>
	<p style="text-align: center;"><b>MODEL : APL - 3N SERIES (APL-310N)</b></p> <ul style="list-style-type: none"> <li>- Enclosure : Weatherproof IP67/NEMA4&amp;4X (Standard ) IP68(Optional)</li> <li>- Solid and beautiful design &amp; various options available <ul style="list-style-type: none"> <li>• 3~4 additional switches</li> <li>• 8~16 points Terminal Strips</li> </ul> </li> <li>- Bolts on visual position indicator</li> <li>- Dual cable entries : 2 x 1/2 NPT(Standard ) M20, PG13.5, PF1/2", PT1/2".(Option)</li> <li>- Terminal Strips : 8 points(0.08-2.5mm<sup>2</sup>)</li> <li>- Captive cover bolts</li> <li>- Easy mounting bracket</li> <li>NAMUR standard stainless steel shaft and stainless steel or steel bracket.</li> </ul>
	<p style="text-align: center;"><b>MODEL : APL - 4N SERIES (APL-410N)</b></p> <ul style="list-style-type: none"> <li>- Enclosure : Weatherproof IP67/NEMA4,4X,7,9 (Standard ) IP68(Optional) Explosionproof : E EX d IIB T6</li> <li>- Solid and beautiful design &amp; various options available <ul style="list-style-type: none"> <li>• 3~4 additional switches</li> <li>• 8~20 points Terminal Strips</li> <li>• various options switches</li> </ul> </li> <li>- Bolts on visual position indicator</li> <li>- Cable entries : 2 x 3/4 NPT(Standard ) M20, M25, PF3/4", PT3/4" 4Cable entries(Optional)</li> <li>- Terminal Strips : 8 points(0.08-2.5mm<sup>2</sup>)</li> <li>- Captive cover bolts</li> <li>- Easy mounting bracket</li> <li>NAMUR standard stainless steel shaft and stainless steel or steel bracket.</li> </ul>
<p style="font-size: 2em; color: red; font-weight: bold;">Select</p>  <div style="text-align: right;">  <p><b>IECEX</b></p> </div>	<p style="text-align: center;"><b>MODEL : APL - 5N SERIES <span style="color: red;">NEW</span> (APL-510N)</b></p> <ul style="list-style-type: none"> <li>- Enclosure : Weatherproof IP67/NEMA4,4X,7,9 (Standard ) IP68(Optional) Explosionproof : E EX d IIC T6, E EX ia IIC T6, E EX d IIB T6</li> <li>- Solid and compact design</li> <li>- Shaft holder built in the cover(Dual shaft) Easy to set the visual position indicator. Unique design to put the visual indicator on the threaded joint type cover.</li> <li>- Bolts on visual position indicator</li> <li>- Dual Cable entries : 2 x 3/4 PF(Standard ) M20, M25, NPT3/4", PT3/4" (Option)</li> <li>- Terminal Strips : 8 points(0.08-2.5mm<sup>2</sup>)</li> <li>- Captive cover bolts &amp; <b>Spring loaded cover bolts (Standard)</b></li> <li>- Easy mounting bracket</li> <li>NAMUR standard stainless steel shaft and stainless steel or steel bracket.</li> <li>- <b>Stainless steel (316) housing as option</b></li> </ul>

## FEATURES

- Solid and flexible design  
Aluminium die-casting housing and powder coating.
- Bolts on visual position indicator
- Quick-set™ cam  
Spring loaded splined cam.  
No need to adjust again after initial setting.  
Easy setting without tool
- Dual cable entries
- Captive cover bolts  
No worry to loose bolts while cover open.  
Spring loaded cover bolts(APL-5N)
- Easy mounting bracket  
NAMUR standard stainless steel shaft and bracket.



## STANDARD SPECIFICATION

Specification \ Model	APL- 2N Series	APL- 3N Series	APL- 4N Series	APL- 5N Series
Enclosure	Weatherproof IP67/NEMA4&4X	Weatherproof IP67/NEMA4&4X	Weatherproof IP67/NEMA4&4X Explosionproof E EX d IIB T6	Weatherproof IP67/NEMA4&4X Explosionproof E EX d IIC T6
Cable entries	Two NPT1/2"	Two NPT1/2"	Two NPT3/4"	Two NPT3/4"
Ambient temperature	-20℃~ 80℃	-20℃~ 80℃	-20℃~ 80℃	-20℃~ 80℃
Terminal strips	8 points (0.08-2.5mm <sup>2</sup> )	8 points (0.08-2.5mm <sup>2</sup> )	8 points (0.08-2.5mm <sup>2</sup> )	8 points (0.08-2.5mm <sup>2</sup> )
Position indicator	0 ~ 90° (90° turn free join) close:red open:yellow	0 ~ 90° (90° turn free join) close:red open:yellow	0 ~ 90° (90° turn free join) close:red open:yellow	0 ~ 90° (90° turn free join) close:red open:yellow
Switches	Mechanical switch x2 proximity sensor x2	Mechanical switch x2 proximity sensor x2	Mechanical switch x2 proximity sensor x2	Mechanical switch x2 proximity sensor x2
Painting	Chromate Polyester podwer coating(black)	Chromate Polyester podwer coating(black)	Chromate Polyester podwer coating(black)	Chromate Polyester podwer coating(black)

## OPTION SPECIFICATION

Specification \ Model	APL- 2N Series	APL- 3N Series	APL- 4N Series	APL- 5N Series
Enclosure	Weatherproof IP68	Weatherproof IP68	Weatherproof IP68	Weatherproof IP68 Explosionproof E EX d IIB T6 E EX ia IIC T6
Cable entries	Two PF1/2", PT1/2" M20, PG13.5	Two PF1/2", PT1/2" M20, PG13.5	FOUR PF3/4", PT3/4" M20, M25	Two NPT3/4" PT3/4"
Option temperature	-	-40℃ ~ 80℃ -20℃ ~ 150℃	-	-
Terminal strips	-	16 points (0.08-2.5mm <sup>2</sup> )	20 points (0.08-2.5mm)	-
Position indicator	three position close:red open:Green	three position close:red open:Green	three position close:red open:Green	three position close:red open:Green
Switches	-	Mechanical switch x4 proximity sensor x4	Mechanical switch x4 proximity sensor x4	Mechanical switch x4 proximity sensor x4
Potentiometer	-	1k ohm standard. 5k ohm. 0-10k ohm	1k ohm standard. 5k ohm. 0-10k ohm	1k ohm standard. 5k ohm. 0-10k ohm
Current output signal unit	-	4~20mA DC 12.5 to 37VDC (24V typical)	4~20mA DC 12.5 to 37VDC (24V typical)	4~20mA DC 12.5 to 37VDC (24V typical)
Painting	Nylon others on request red, green, blue, yellow, silver	Nylon others on request red, green, blue, yellow, silver	Nylon others on request red, green, blue, yellow, silver	Nylon others on request red, green, blue, yellow, silver

### APL-2N & APL-3N Weatherproof Design

#### Enclosure

Solid and beautiful design  
aluminium die-casting  
IP67



APL-210N

#### Painting

Powder coating

#### Housing Body

Aluminium die-casting



#### Quick-Set Cam

Easy to set, Splined cam  
Open-Yellow, Close-Red

#### O-rings

#### Various Switches

Mechanical  
Proximity(P & F)  
Reed & Pneumatic

#### Shaft

Stainless steel  
NAMUR

#### Mounting Bracket

#### Visual Position Indicator

Poly-carbonated  
Open-Yellow, Close-Red

#### Name Plate

#### Housing Cover

Aluminium die-casting

#### Captive Bolts

Stainless steel

#### Terminal Strip

Standard 8 points

#### Earth lug

#### Multi-Ports

Main.2Ports  
APL-4N:Max.4Ports



APL-310N



## APL-4N & APL-5N Explosionproof Design

### Enclosure

Solid and beautiful design  
aluminium die-casting  
IP67 & Explosionproof  
design

### Painting

Powder coating

### Housing Body

Aluminium die-casting

### Quick-Set Cam

Easy to set, Splined cam  
Open-Yellow, Close-Red

### O-rings

### Various Switches

Mechanical  
Proximity(P & F)  
Reed & Pneumatic

### Shaft

Stainless steel  
NAMUR

### Mounting Bracket



APL-410N

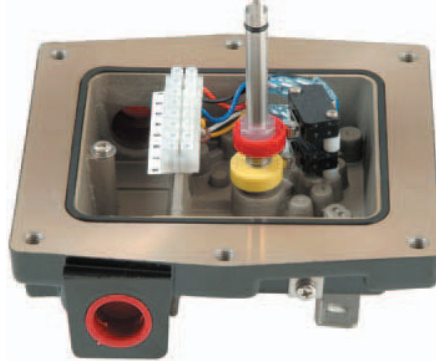

APL-510N



### Visual Position Indicator

Poly-carbonated  
Open-Yellow, Close-Red

### Name Plate

Standard 8 points

### Housing Cover

Aluminium die-casting

### Captive Bolts

Stainless steel

### Terminal Strip

Standard 8 points

### Earth lug

### Multi-Ports

Main.2Ports  
APL-4N:Max.4Ports

# SWITCH SPECIFICATION

## - Mechanical switch -

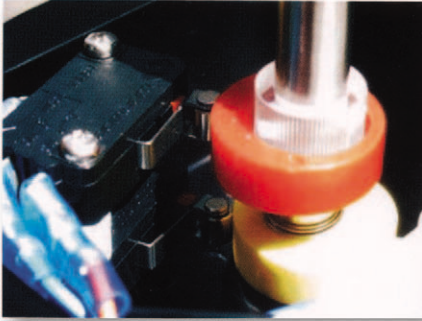

### Standard switches

2SPDT switches  
 Contact arrangement:  
 250VAC/16A, 250VDC/0.3A  
 125VDC/0.6A, 30VDC/10A,

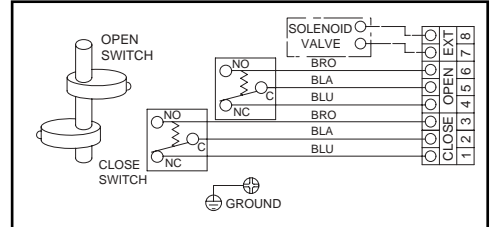

- Operating frequency  
 600 operating per minute max (mechanical)  
 60 operating per minute max (electrical)

### Option switches

3SPDT switches  
 Contact arrangement:  
 250VAC/16A, 250VDC/0.3A  
 125VDC/0.6A, 30VDC/10A,  
 Except APL 2N series

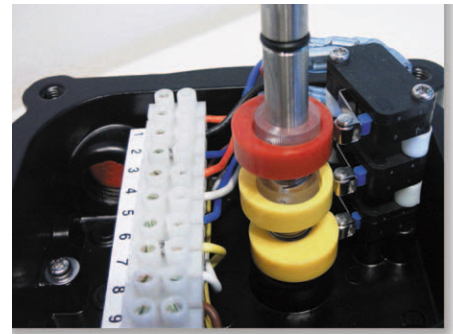

### Option switches

4SPDT switches  
 Contact arrangement:  
 250VAC/16A, 250VDC/0.3A  
 125VDC/0.6A, 30VDC/10A,  
 Except APL 2N series

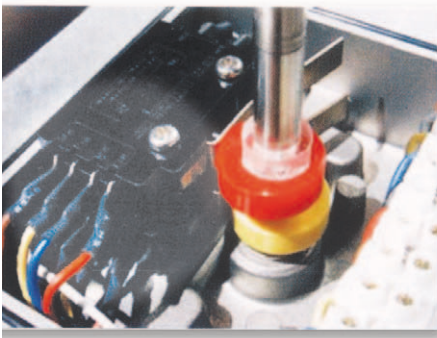
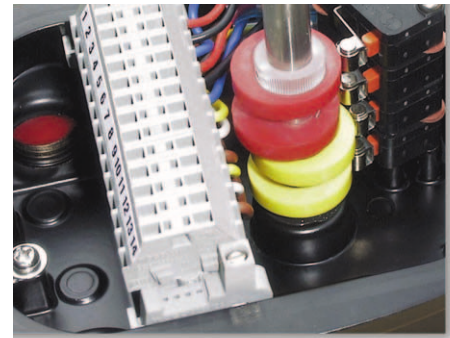
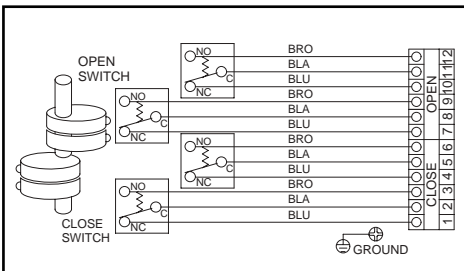

### DPDT switches

Contact arrangement:  
 20amp 125/250VAC  
 1HP 125 VAC  
 2HP 250VAC  
 0.5amp 250VDC  
 Except APL 2N, 3N, 5N series

## SWITCH SPECIFICATION

### - Proximity sensor -

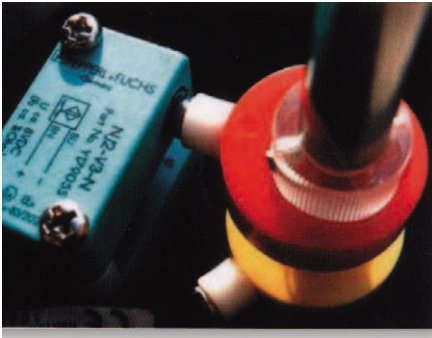

#### **NJ2-V3-N P&F**

(intrinsically safe)  
Inductive proximity sensor  
Voltage range : 8V DC  
Operating distance : 2mm

#### **NPS17-5DN**

Inductive proximity sensor  
Voltage range : 10~30V DC  
AC110V or 220V  
Operating distance : 5mm  
Except APL 2N series

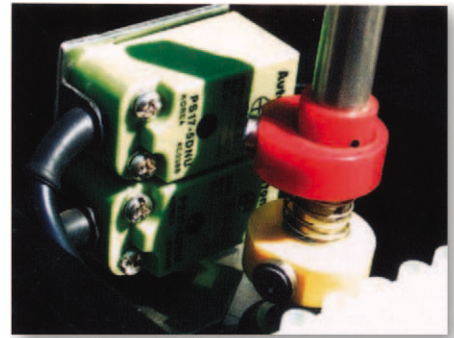

#### **Optional sensor**

NBB2-V3-E2/E3(PNP) : 10-30V DC  
NBB2-V3-E0(NPN) : 10-30V DC  
NBB2-V3-Z4/Z5 : 5-60V DC

APL 4N Proximity sensor  
NJ2-12GM-40-E2 : 10-60V DC  
NJ4-12GM-40-E2 : 10-60V DC  
NBB2-12GM-40 : 6-60V DC  
Except APL2, 3, 5N series

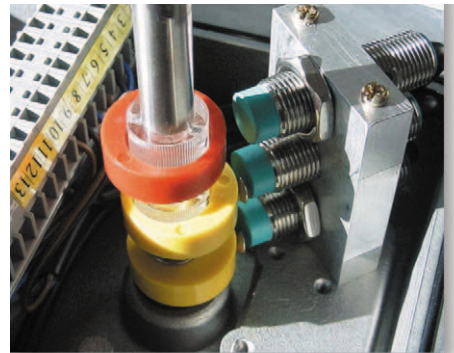

### - Reed proximity sensor -



#### **2SPST switches**

Contact Form : NO. NC  
Contact Rating : 10W max  
Switching Voltage : 200VDC max  
Switching Current : 1A max  
Breakdown Voltage : 250VDC min  
Contact Resistance(initial) : 0.3 Ohm max  
Electrical Life :  $10^7$ (6VDC, 10mA)

## STRUCTURE

### APL-5N Series

-Top visual position indicator

- Dual shaft

-Threaded joint design

-Namur standard shaft

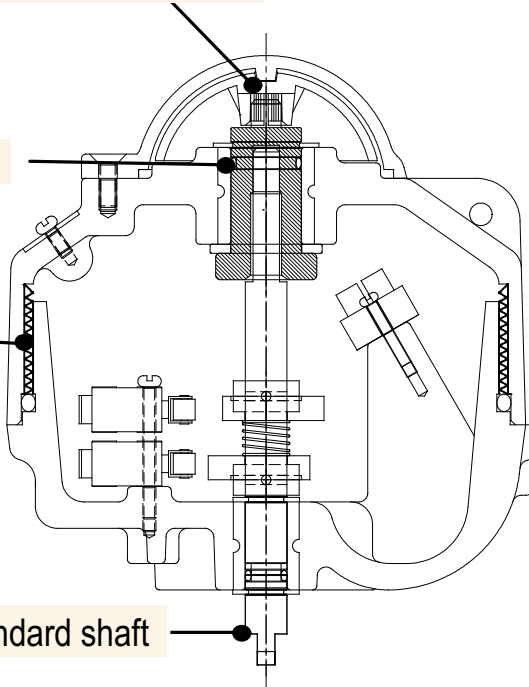

### Captive spring-loaded cover bolts

cover bolts are specially designed to prevent losing it during maintenance or installation. (APL 5N Series)



### Position monitor

Continuous visual position indicator  
 Made of high impact, heat, chemical resistance and transparent carbonate  
 Excellent corrosion protection  
 High visibility and reliability

\*Re-adjustment available upon required direction  
 (APL2,5N SERIES)



(APL3,4N SERIES)

### Flow port Monitor



L port, T port 3-way valve

### Material

Housing cover&body	Aluminium die casting	O -ring	NBR
Shaft	Stainless steel	Bushing	Bronze
Indicator cover	Polycarbonate	E-ring(shaft)	Stainless steel
Cam	Polycarbonate	Earth lug	Stainless steel
Spring	Stainless steel	Indicator	ABS/Polycarbonate
Housing cover bolt	Stainless steel	Bracket	Stainless steel



## ELECTRICAL CONNECTION

### - Position transmitter & potentiometer -

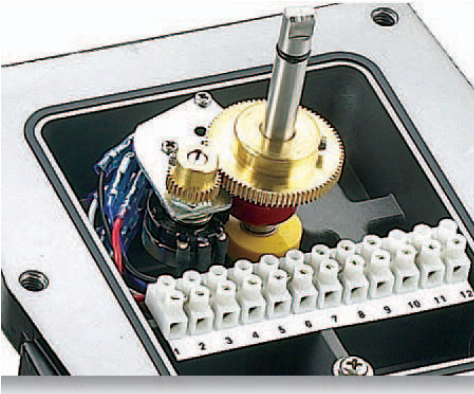

#### Potentiometer

Potentiometer : 500~10K Ohm  
 Operating Temperature : -20 to 80  
 Except APL 2N series

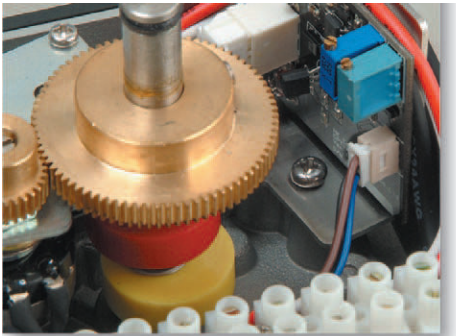

#### Position Transmitter

Power Supply Range : 12.5 to 37VDC (24V typical)  
 Output signal range : 4~20mA  
 Potentiometer : 0~1K Ohm  
 Operating Temperature : -20 to 80  
 Except APL 2N series

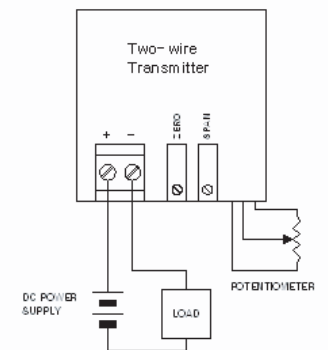

**Wiring**

#### Power Supply Requirements

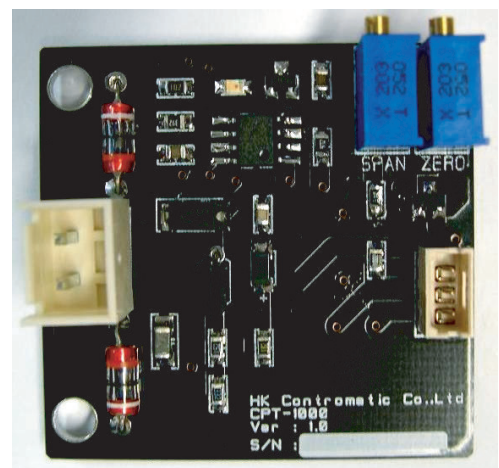
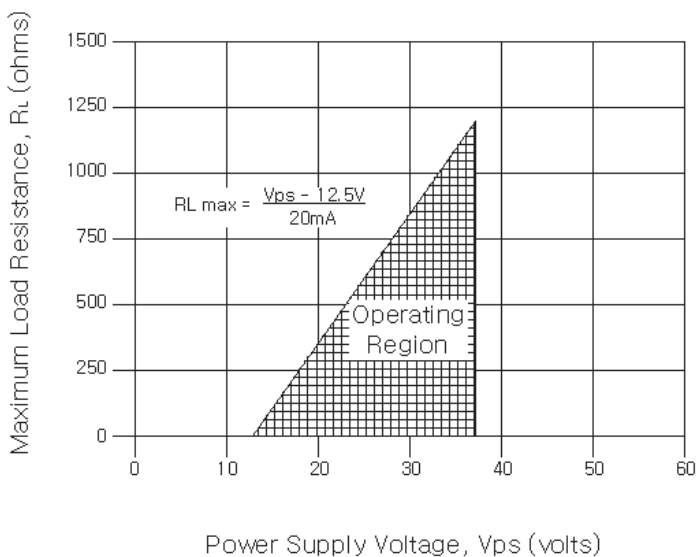

**CPT Card**

## DIMENSION

UNIT : mm

### APL 2N SERIES

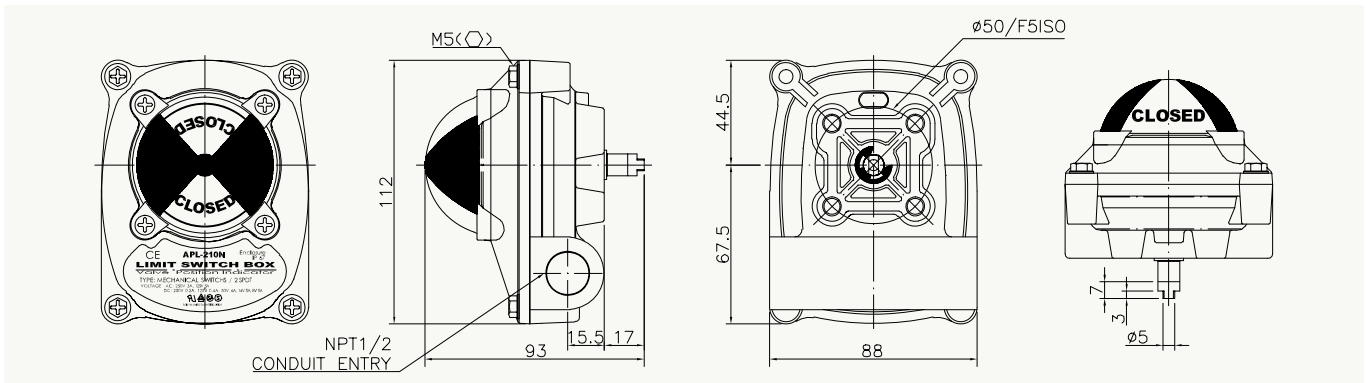

STANDARD NAMUR SHAFT

### APL 3N SERIES

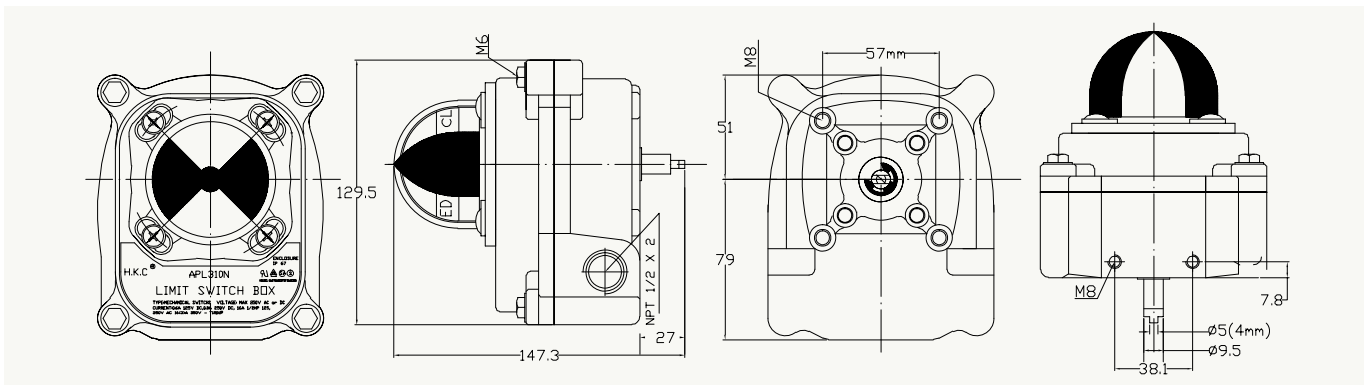

STANDARD NAMUR SHAFT

### APL 4N SERIES

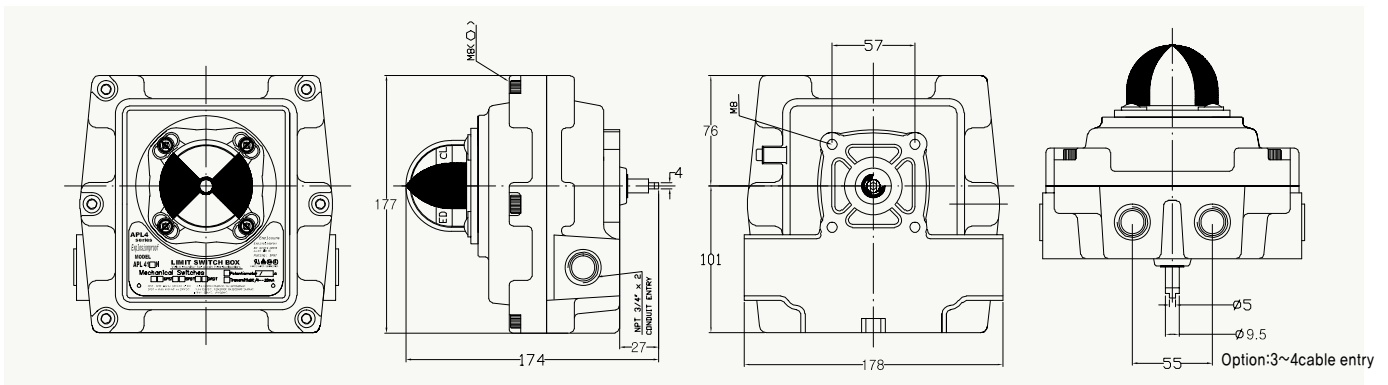

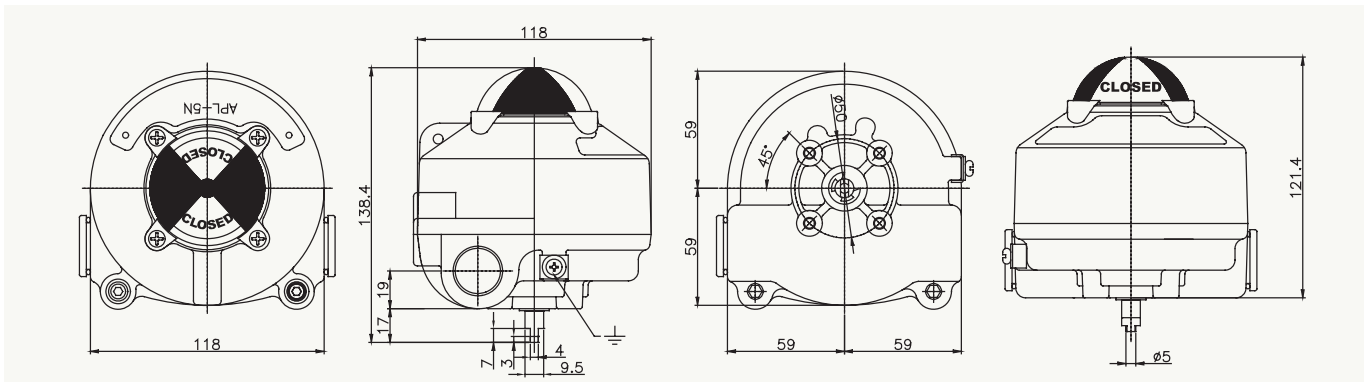

STANDARD NAMUR SHAFT

### APL 5N SERIES



STANDARD NAMUR SHAFT

## BRACKET NAMUR STANDARD

<b>Shape</b>			
<b>Size</b>	25 × 50 H:20 30 × 80 H:20 30 × 80(130) H:30(50)	30 × 80 H:20 30 × 80 H:30	30 × 130 H:30 30 × 130 H:50
<b>Model</b>	MBP-50 MBP-100 MBP-200 MBP-300 MBP-400	MB-P-O-1C MB-P-O-1S MB-P-O-2C MB-P-O-2S	MB-P-O-3C MB-P-O-3S MB-P-O-4C MB-P-O-4S

● Last alphabet in model, C means plate steel, S means stainless steel



Hologram shall be put on all products manufactured in the "HKC" factory.

## ORDERING INFORMATION

APL - 2 1 0 N

Enclosure \_\_\_\_\_

- 2. Enclosure
- 3. Weather proof
- 4. Explosion proof(E Exd IIB T6)
- 5. Explosion proof(E Exd IIC T6)

Switch type \_\_\_\_\_

Bolt on  
Position Indicator

Mechanical switch	Proximity sensor	Reed type proximity sensor
10 2-SPDT	20 P & F NJ2-V3-N	30 General type
11 3-SPDT	21 Autonics. PS17-5DNU	
12 4-SPDT	22 P & F NJ4-12GM-N	
13 2-SPST	23 NBB2- V3	
14 2-DPDT		
15 2-SPDT + Potentiometer		
16 2-SPDT + Signal unit (4-20mA)		



**Hologram shall be applied to all products manufactured in HKC.  
No goods without hologram shall be accepted for warranty.**



**KOSH** 2001-1109-Q1. 2001-1109-Q1.  
2006-1171-Q1.



**ATEX** NEMKO 06A ATEX 1284X



**IECEX** K0506. 0001X



**NEPSI** GYJ05227/GYJ05226

### Factory

**HK Contromatic Co., Ltd.**  
425-110, 4ba-720 Sunggok-Dong,  
Ansan-shi, Kyungki-Do, Korea

### Agent : **DDD Enterprise Co., Ltd.**

NO.11, SEC.1 Shi Ping RD., Shijhih City, Taipei County 22172, Taiwan

Tel: 886-2-86483176 Fax: 886-2-86475088 <http://www.autovalve.tw> E-Mail: [service@autovalve.tw](mailto:service@autovalve.tw)